

Represented by



ILLING[®]
Company, Inc.
Packaging Your Vision

Product Specification Sheet

Illing Part# 3585

3.5 OZ. CLEAR PET PLASTIC SPICE JAR, 43-485

Part #: 3585

Size:	3.5 oz.
Color:	Clear
Material:	PET
Style:	Spice Jar & Dry Food Container
Additional Info:	43-485
Case Pack:	700 each
Pallet Pack:	- each

ENVISION
DESIGN DECORATE DELIVER

LabelILLING™

AI SMART
PACKAGING

ILLING
GLOBAL
SOURCING

www.illingcompany.com

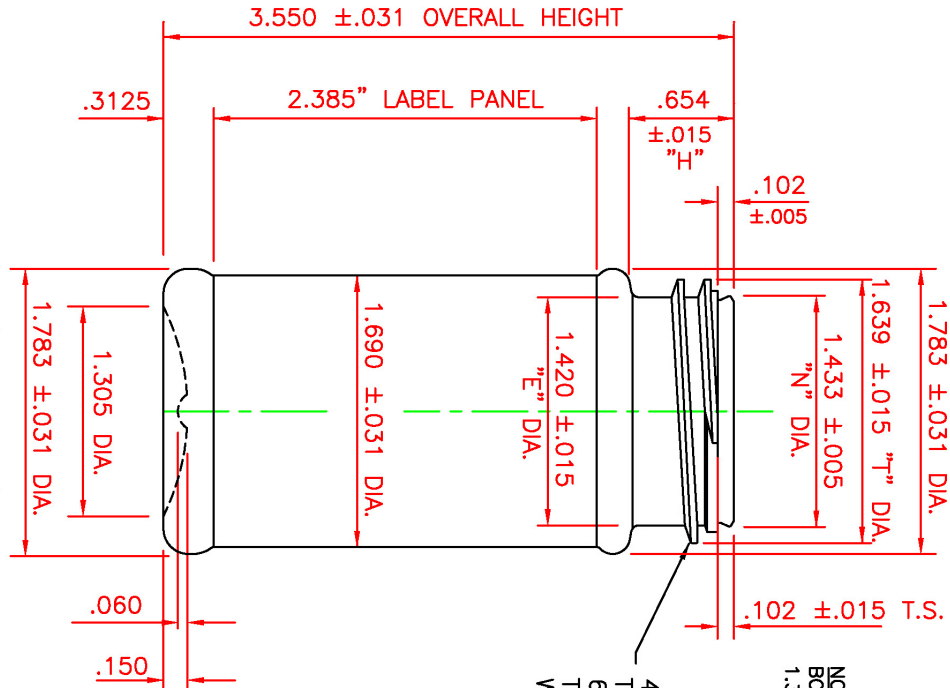

SCALE: FULL

NOTE:
BOTTLE I.D. SPEC.
1.318 ±.015"

43MM-485
THREAD FINISH,
6 T.P.I., 1-1/4
TURN OF THREAD
WRAP

RECYCLE LOGO
ON UNDERSIDE

ENGRAVE
CAPACITY
3.5 oz.

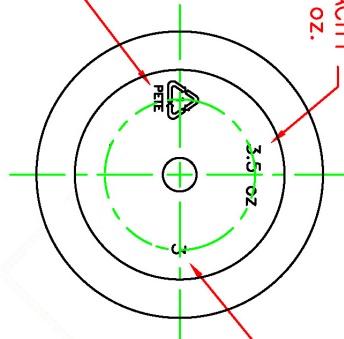

CAVITY NUMBERS ON
UNDERSIDE

NOTES:
ALL DIAMETER DIMENSIONS
ARE AN AVERAGE OF (2)
MEASUREMENTS, WHICH ARE
90 DEGREES APART
MATERIAL: PETE
NOMINAL WEIGHT: [15.0 ±.75] GRAMS
NOMINAL O/F CAPACITY: [110 ±4.1 cc]
THREAD DATA: 43MM-485 THREAD
FINISH, 6 T.P.I., 1-1/4
TURN OF THREAD WRAP
MINIMUM ALLOWABLE WALL SECTION .009" AT ANY
GIVEN LOCATION.

12-22-2010	FPM	SEE ENGINEERING DRAWING FOR DETAILED LISTING OF REVISIONS
------------	-----	--

TOLERANCES UNLESS SPECIFIED		TITLE	
3 PLACE .XXX ± .015	2 PLACE .XX ± .005	3.5 oz. PETE BOTTLE	
1 PLACE .X ± .005	ANGULAR DIMS. ± 1/2	DRAWN BY:	MINKEMEYER
		APPROVED BY:	SCALE AS NOTED
		MATERIAL:	PETE
		MOLD NUMBER:	1536-A1-A
		DRAWING NUMBER:	1536-A1-A